

Strain Ring with Axial Cable Exit DSRC AX

Features

- Ideal for use with telemetry system
- For tension and compression measurement
- Installation without surface preparation
- For cyclical applications only



Strain Gage Data

Strain gage type	Foil gages
Bridge resistance at 24 °C	350 Ω 2 x quarter bridge (without cable)
Sensitivity at 24 °C	Gage factor K= 2.00 ±0,5% (compensated with resistors)
Temp. compensation	Steel
Transverse sensitivity nominal	+0,7%
Bridge circuit	2 x 1/4 bridge (see electrical connections)

Mechanical Data

Connection	Open leads
Material	
- Ring	Aluminum anodized
- Protective foil	Stainless steel
- Screws	M8 (torque 3 Nm)
- Hinge	Nitril
Cable	5 m 2 core, shielded, PVC

Environmental Conditions

Surface installation spot	Ra 3.2 (N8) or better
Operating temp. range	-10...+60 °C
Storage temperature	-40...+100 °C
Protection class	IP 54

Electrical Data

Measuring range	±1000 µε (1 µε = 0,001 mm/m resp. 1 µε equals 0,001 mm strain per meter of shaft)
Output signal per 1000 µε	1 mV/V (with completed full bridge)
Combined error	< 1% FS
Linearity	< 0,5% FS
Hysteresis	< 0,5% FS
Repeatability	< 0,2% FS
Zero, bridge balance	< ±200% FS (depending on installation) Since the gages are pressed-on, the bridge can have any arbitrary zero offset after the ring is mounted. Baumer amplifiers and display boxes are equipped with a reset function to tare this offset. The bridge should be reset before each measuring cycle.
Excitation max.	9 VDC
Recommended	5 VDC
Signal polarity	The signal polarity depends on the bridge circuit. In combination with Baumer amplifiers, the polarity is positive under tensile load.
Rise time (10 - 90%)	< 1 ms (on steel)

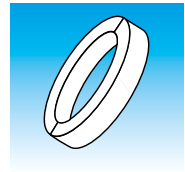

Dimensions (mm)

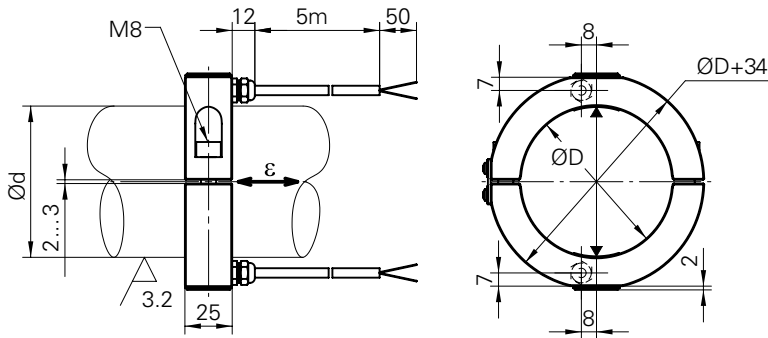

$\varnothing d = \varnothing D \begin{matrix} +0,1 \\ -0,5 \end{matrix}$

- Ø D = Nominal diameter
- Ø d = Shaft diameter
- ε = Strain
- ▲ = Gage location

Electrical Connections

Bridge Circuit

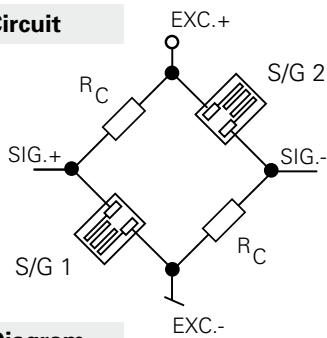

Wire Color

(per ring half)

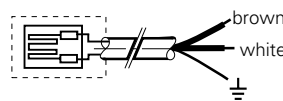

Color	Signal
brown	S/G
white	S/G

Option /CN

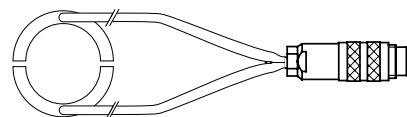

Series 423

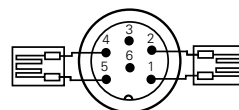

Pin	Signal
1	S/G 1
2	S/G 1
3	n.c.
4	S/G 2
5	S/G 2
6	n.c.

Wiring Diagram

